

CLEARANCE SALE

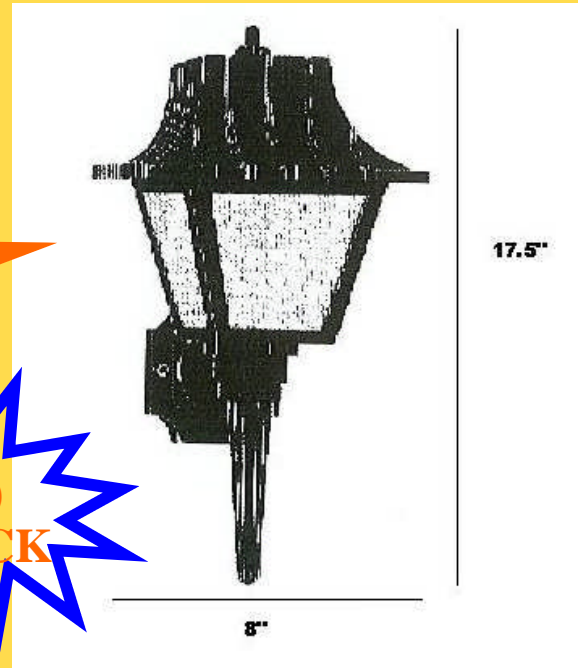

OUTDOOR DECORATIVE

- POLYCARBONATE WALL
LANTERN WITH FLEMISHED LENS



100
WHITE

SALE
PRICE
\$6.95

400
BLACK

6 LANTERNS/CARTON
MINIMUM ORDER: 6

FREIGHT: EXTRA
FIRST COME BASIS ONLY

ORDERS THROUGH: Marketing Energy (2000) Ltd. 621 Clarke Road London, ON Canada N5V 2E1 Phone: 519-457-7522 Fax: 519-457-0338 E-mail: stacey@taylormg.com